

# HEAT R 2g S 81.51.40.01

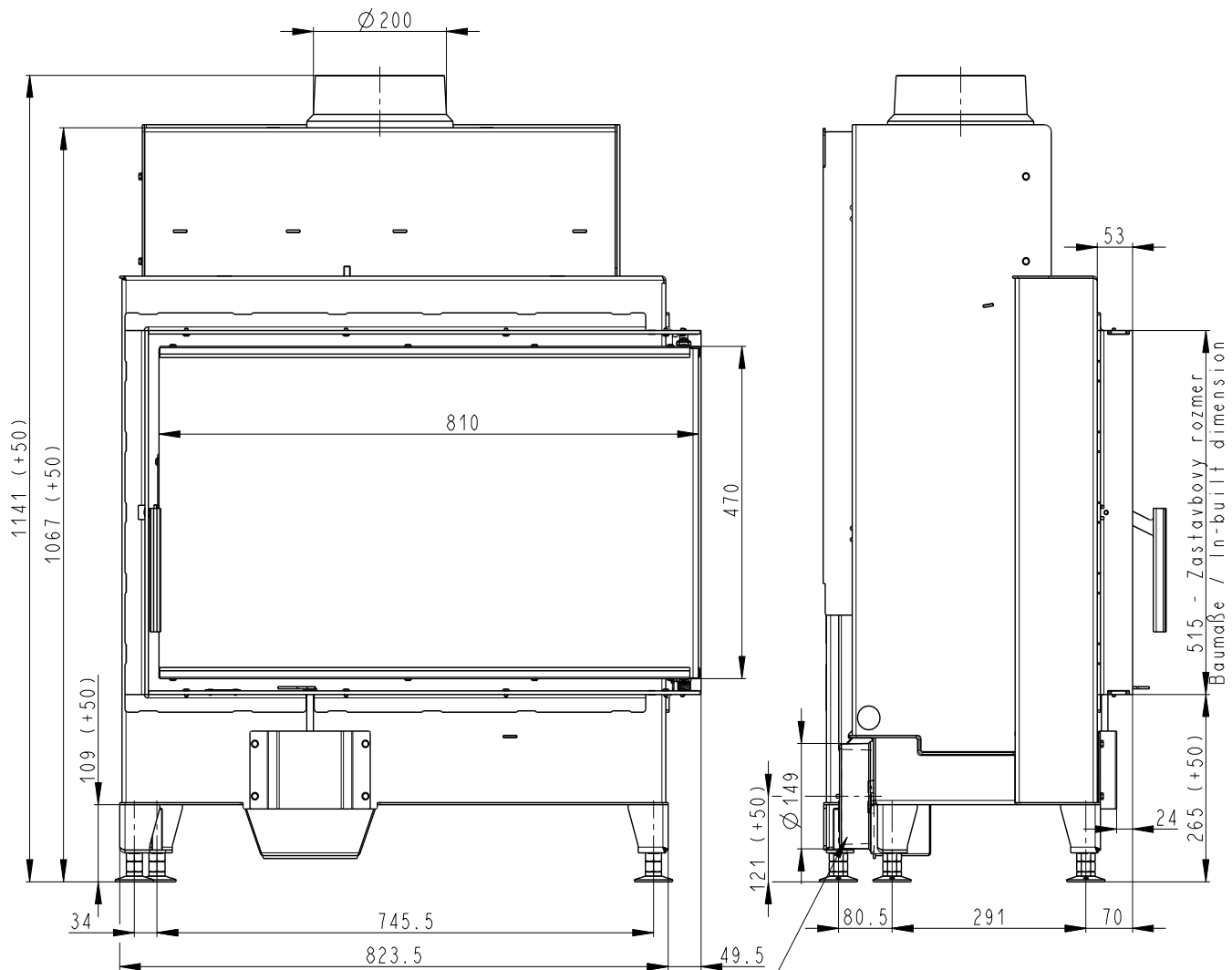

Centralni privod vzduchu  
Central air inlet  
Zentralluftzufuhr

Litiny odvod koure - Cast iron spigot - Der gusseiserne Rauchabgang

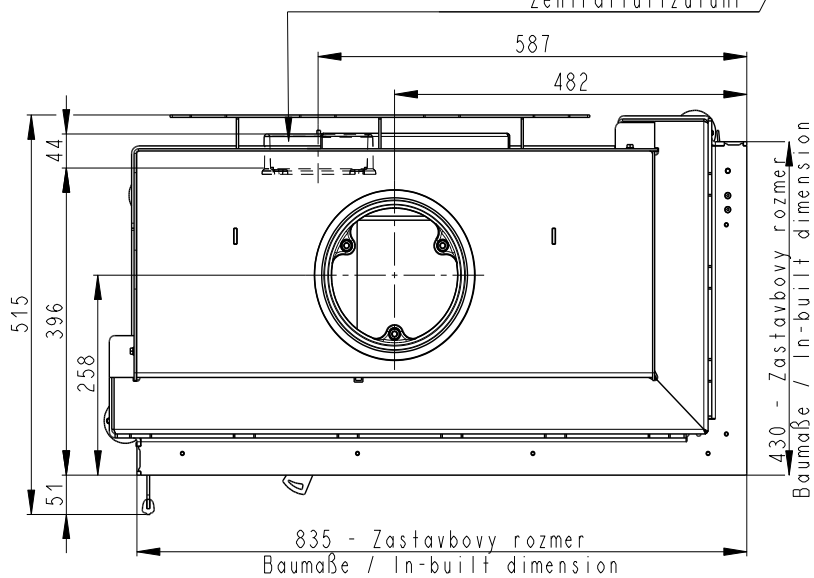

Primarni a sekundarni vzduch  
Primärluft und Sekundärluft  
Primary and secondary air

Artikl	HR2SF 01
--------	----------

#### General data

Nominal heat output	kW	12,0
Efficiency	%	83,25
Mass of the test fuel fired hourly	kg/h	3,40
Dry flue gases mass flow	g/s	9,9
Mean flue gas temperature	°C	223
Flue draught	Pa	12
Weight	kg	190
CO <sub>2</sub>	%	10,02

#### Recommended values

Reg.output	kW	6 – 15,5
Max. mass of the test fuel fired hourly	kg/h	5,8
Min. cross section of convect air inlet for nominal output	cm <sup>2</sup>	880
Min. cross section of convect air outlet for nominal output	cm <sup>2</sup>	1120
Combustion air requirement	m <sup>3</sup> /h	11,3
Flue gas connector diameter	mm	200

#### Meets requirement limit values for

EN 13 229	•
BImSch V 1	•
BImSch V 2	•
DIN plus	•
15a B-VG	•

#### Supplied accessories

Holder with magnet	•
Hook to open the ashtray	-
Ashtray	-

# HEAT L 2g S 81.51.40.01

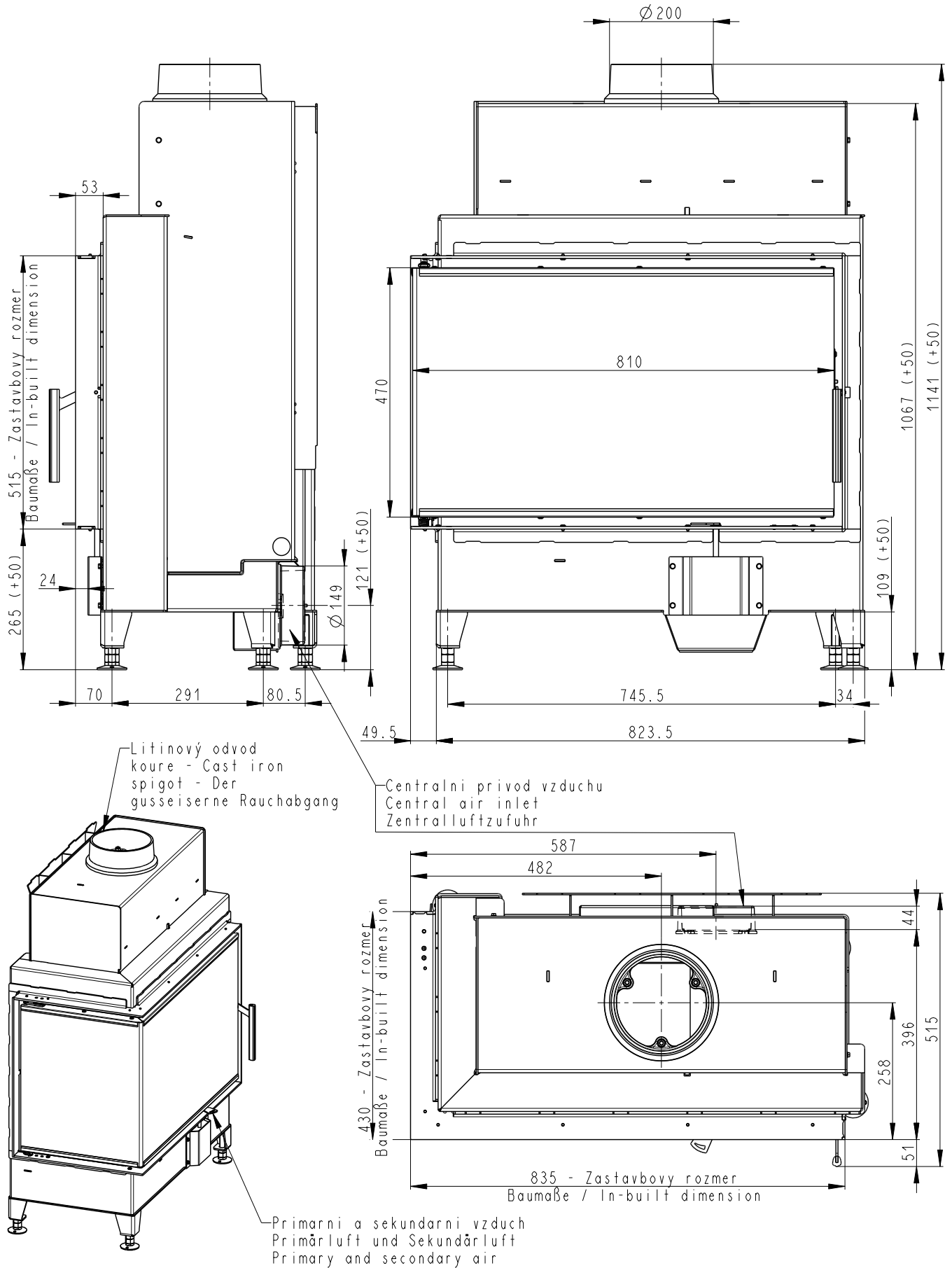

Artikl	HL2SF 01
--------	----------

#### General data

Nominal heat output	kW	12,0
Efficiency	%	83,25
Mass of the test fuel fired hourly	kg/h	3,40
Dry flue gases mass flow	g/s	9,9
Mean flue gas temperature	°C	223
Flue draught	Pa	12
Weight	kg	190
CO <sub>2</sub>	%	10,02

#### Recommended values

Reg.output	kW	6 – 15,5
Max. mass of the test fuel fired hourly	kg/h	5,8
Min. cross section of convect air inlet for nominal output	cm <sup>2</sup>	880
Min. cross section of convect air outlet for nominal output	cm <sup>2</sup>	1120
Combustion air requirement	m <sup>3</sup> /h	11,3
Flue gas connector diameter	mm	200

#### Meets requirement limit values for

EN 13 229	•
BImSch V 1	•
BImSch V 2	•
DIN plus	•
15a B-VG	•

#### Supplied accessories

Holder with magnet	•
Hook to open the ashtray	-
Ashtray	-